

JVC

SERVICE MANUAL

COLOUR TELEVISION

BASIC CHASSIS

JK

AV-25PS_(M)

This service manual mainly consists of the following items:

- The items which differ from those for the AV-25PS service manual.
- The initial value for each setting item.

For details other than those described in this manual, please refer to the following service manual.

Reference Service Manual: AV-25PS Service Manual (No. 51750, Jul. 2000)

Note: The page in parentheses shows the one for the AV-25PS service manual (No. 51750, Jul. 2000).

HOW TO IDENTIFY MODEL

While referring to the illustration given below, identify model name on the rating label affixed to the rear cover.

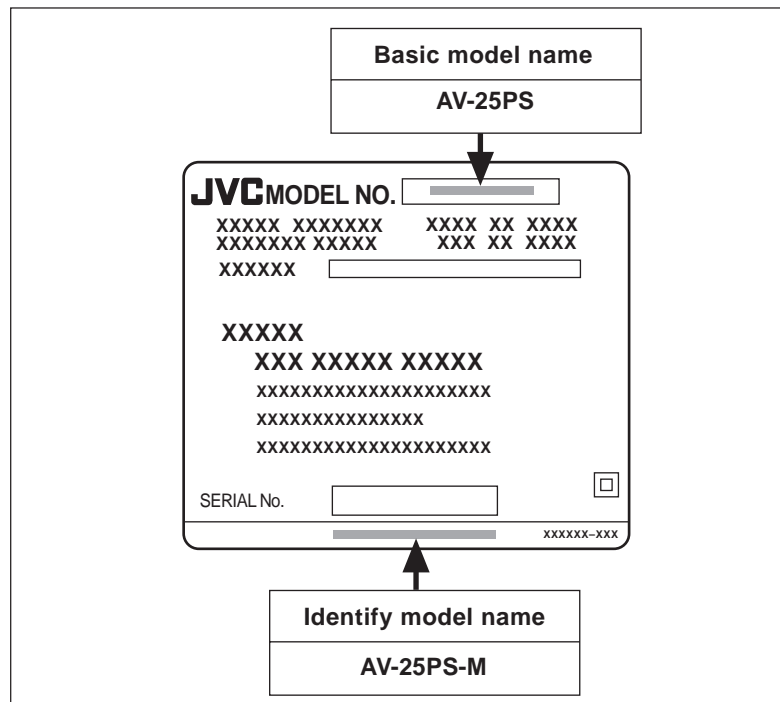

PARTS DIFFERENCE TABLE

The different parts between AV-25PS and AV-25PS(M) are described below:

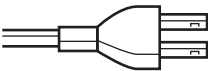
| ⚠ | REF. NO. | AV-25PS | AV-25PS(M) | PART NAME | DESCRIPTION |
|---|----------|--|--|------------------|-------------|
| | | PART No. | PART No. | | |
| ■ EXPLODED VIEW PARTS LIST (Page 36) | | | | | |
| ⚠ | 10 | QMP40D0-200J3 or QMP40D0-200J5  | QMPR010-200-E2 or QMPR010-200-K2  | POWER CORD | |
| ■ PACKING PARTS LIST (Page 47) | | | | | |
| | — | — | CM47385-00B-H | POS/SERIAL LABEL | |
| | — | — | GG30014-008A-H | POS UPC LABEL | |
| ⚠ | — | — | QAM0055-001 | CONVERSION PLUG | |

SPECIFICATIONS (Page 2)

| Item | | CONTENTS |
|-------------------------------------|--------------------|---|
| Dimensions (W × H × D) | | 655mm × 530.5mm × 465mm |
| Mass | | 36kg |
| TV RF System | | B, G, I, D, K, K1, M |
| Colour System | | PAL, SECAM, NTSC3.58, NTSC4.43 |
| Stereo System | | A2 / NICAM (B/G, I, D/K) |
| Teletext System | | FLOF (Fastext), WST (World standard system) |
| Receiving Frequency | VHF (L) | 46.25MHz ~ 168.25MHz |
| | VHF (H) | 175.25MHz ~ 463.25MHz |
| | UHF | 471.25MHz ~ 863.25MHz |
| | CATV | Mid (X-Z, S1-S10), Super (S11-S20), Hyper (S21-S41) bands receivable |
| Intermediate Frequency | | |
| | VIF Carrier | 38.0MHz |
| | SIF Carrier | 33.5MHz(4.5MHz), 32.5MHz(5.5MHz), 32.0MHz(6.0MHz), 31.5MHz(6.5MHz) |
| Colour Sub Carrier Frequency | | |
| | PAL | 4.43MHz |
| | SECAM | 4.40625MHz, 4.25MHz |
| | NTSC | 3.58MHz / 4.43MHz |
| Power Input | | AC110 ~ 240V, 50/60Hz |
| Power Consumption | | 181W (Max.), 119W (Avg.) |
| Picture Tube | | Visible size : 60cm measured diagonally |
| High Voltage | | 31.0kV ±1.5kV (at zero beam current) |
| Speaker & Audio Output | | Open dome speaker 10W+10W, 10cm round x 2 |
| Video Audio Input terminals | | |
| Video1 | S-Video | Y: 1Vp-p Positive (Negative sync provided, when terminated with 75Ω) C: 0.286Vp-p (Burst signal, when terminated with 75Ω) |
| | Video | 1Vp-p 75Ω (RCA pin jack) |
| | Audio (L/R) | 500mVrms (-4dBs), High impedance (RCA pin jack) |
| Video2 | Video | 1Vp-p 75Ω (RCA pin jack) |
| | Audio (L/R) | 500mVrms (-4dBs), High impedance (RCA pin jack) |
| Video3 | Video/Y | Composite video 1Vp-p 75Ω (RCA pin jack) Component video 1Vp-p 75Ω (RCA pin jack) |
| | Cb | Component video B-Y 0.7Vp-p 75Ω (RCA pin jack) |
| | Cr | Component video R-Y 0.7Vp-p 75Ω (RCA pin jack) |
| | Audio (L/R) | 500mVrms (-4dBs), High impedance (RCA pin jack) |
| Video4 | Video | 1Vp-p 75Ω (RCA pin jack) |
| | Audio (L/R) | 500mVrms (-4dBs), High impedance (RCA pin jack) |
| Video Audio Output terminal | | |
| | Video | 1Vp-p 75Ω (RCA pin jack) |
| | Audio (L/R) | 500mVrms (-4dBs), High impedance (RCA pin jack) |
| Aerial Input Terminal | | 75Ω Unbalanced, Coaxial |
| Headphone Jack | | Stereo mini jack (3.5ø) |
| AV Compu Link terminal | | AV Compu Link II, mini jack (3.5ø) |
| Remote Control Unit | | RM-C112 (AA/R06 / UM-3 dry battery × 2) |

Design & specifications are subject to change without notice.

SPECIFIC SERVICE INSTRUCTIONS

SETTING OF SYSTEM CONSTANT SET (Page 9)

Table 1

| CONTENTS | VARIABLE RANGE | INITIAL SETTING VALUE |
|----------------|--|-----------------------|
| COLOUR | <input type="checkbox"/> MULTI <input type="checkbox"/> TRIPLE <input type="checkbox"/> PAL <input type="checkbox"/> | MULTI |
| MSP | <input type="checkbox"/> YES <input type="checkbox"/> NO <input type="checkbox"/> | YES |
| SUPER BASS | <input type="checkbox"/> YES <input type="checkbox"/> NO <input type="checkbox"/> | NO |
| CENTER SPEAKER | <input type="checkbox"/> YES <input type="checkbox"/> NO <input type="checkbox"/> | NO |
| TEXT | <input type="checkbox"/> YES <input type="checkbox"/> NO <input type="checkbox"/> | YES |
| BLUE BACK MUTE | <input type="checkbox"/> YES <input type="checkbox"/> NO <input type="checkbox"/> | NO |
| VOLUME LIMIT | <input type="checkbox"/> YES <input type="checkbox"/> NO <input type="checkbox"/> | YES |
| COLOUR AUTO | <input type="checkbox"/> YES <input type="checkbox"/> NO <input type="checkbox"/> | NO |
| TILT | <input type="checkbox"/> YES <input type="checkbox"/> NO <input type="checkbox"/> | YES |
| C-TRAP | <input type="checkbox"/> 1 <input type="checkbox"/> 0 <input type="checkbox"/> | 1 |
| E.M.C. | <input type="checkbox"/> YES <input type="checkbox"/> NO <input type="checkbox"/> | NO |
| N/S WHITE BACK | <input type="checkbox"/> YES <input type="checkbox"/> NO <input type="checkbox"/> | NO |
| 7 LED SPEED | <input type="checkbox"/> 00 <input type="checkbox"/> 10 <input type="checkbox"/> 20 <input type="checkbox"/> ... <input type="checkbox"/> 1250 <input type="checkbox"/> 1270 <input type="checkbox"/> 1260 <input type="checkbox"/> | 00 |

USER SETTING CONDITIONS (Page 9)

Table 2

| PICTURE SETTING | | FEATURES | |
|------------------|---|-------------------|----------------------------------|
| PICTURE MODE | BRIGHT | SLEEP TIMER | OFF |
| CONTRAST | CENTER | ON TIMER | PR1 0:00 |
| BRIGHT | CENTER | BLUE BACK | ON |
| SHARP | CENTER | CHILD LOCK | OFF |
| COLOUR | CENTER | CHANNEL GUARD | -- |
| TINT | CENTER | AUTO SHUT OFF | OFF |
| WHITE BALANCE | COOL | VIDEO-3 SETTING | COMPONENT |
| PICTURE FEATURES | | INSTALL | |
| A.A.C | ON | LANGUAGE | ENGLISH |
| AUTO VNR | AUTO | AUTO PROGRAM | -- |
| COLOUR SYSTEM | TV: According to preset CH VIDEO: AUTO PAL | EDIT / MANUAL | PRESET CH only Others: blank |
| ZOOM | REGULAR | DEMO | |
| ECO SENSOR | OFF | DEMO | OFF |
| PICTURE TILT | CENTER | OTHERS | |
| SOUND SETTING | | VOLUME | Appropriate sound level |
| SETERO / I • II | <input type="radio"/> | CHANNEL PRESET | Refer to Operating Instructions. |
| BASS | CENTER | CHANNEL POSITION | 1 POSITION |
| TREBLE | CENTER | SUB POWER | ON |
| BALANCE | CENTER | ON SCREEN DISPLAY | POSITION INDICATION |
| AI VOLUME | ON | TV/VIDEO | TV |
| BBE | ON | SOUND SYSTEM | B/G |
| SPATIALIZER | OFF | | |

SERVICE ADJUSTMENTS

■ Initial Setting Value

■ SETTING OF VSM PRESET (Page 18)

[INITIAL SETTING VALUES OF VSM PRESET (SUB MENU 5. VSM PRESET)]

| ITEM \ PICTURE MODE | BRIGHT | STANDARD | SOFT |
|---------------------|--------|----------|------|
| 1. BRIGHT | +0 | +0 | +0 |
| 2. CONT | +17 | +0 | -4 |
| 3. COLOR | +0 | +0 | -1 |
| 4. SHARP | +0 | +0 | -3 |
| 5. TINT | +0 | +0 | +0 |

: Do not adjust.

■ SETTING OF WHITE BALANCE PRESET (Page 19)

[SETTING OF WHITE BALANCE PRESET (SUB MENU 6. WB PRESET)]

| ITEM \ WHITE BALANCE | COOL | MID | WARM |
|----------------------|------|-----|------|
| 1. R DRIVE | 0 | -3 | +26 |
| 2. B DRIVE | 0 | -23 | -27 |

: Do not adjust.

■ VIDEO / CHROMA CIRCUIT ADJUSTMENT (Page 19)

| CONTENTS | | PAL | SECAM | NTSC 3.58 | NTSC 4.43 |
|-----------------|------------|-----|-------|-----------|-----------|
| 1. CUTOFF | R | -60 | | | |
| | G | -60 | | | |
| | B | -60 | | | |
| 2. DRIVE | R | +0 | | | |
| | B | +0 | | | |
| 3. BRIGHT | TV | 0 | 0 | 0 | — |
| | VIDEO | +1 | -4 | -2 | — |
| | COMPONENT | -3 | | | |
| 4. CONT | TV | 0 | 0 | 0 | — |
| | VIDEO | +2 | 0 | +2 | — |
| | COMPONENT | +2 | | | |
| 5. COLOUR | TV / VIDEO | +10 | +18 | +0 | -2 |
| | COMPONENT | +8 | | +18 | |
| 6. TINT | TV | +6 | +6 | -1 | 0 |
| | VIDEO | +6 | +6 | +6 | 0 |
| | COMPONENT | +6 | | -3 | |
| 7. BLACK OFFSET | R-Y | — | 0 | — | — |
| | B-Y | — | 0 | — | — |
| 8. SHARP | TV | -15 | -17 | -15 | — |
| | VIDEO | -13 | -11 | -12 | — |
| | COMPONENT | -15 | | | |

 : Do not adjust.

Adjustment of SUB COLOUR-II (Page 22)

| Adjustment part | Description |
|------------------|---|
| 5. COLOUR | |
| PAL COLOUR | Value (A) in the figure: Set to 0V (W & G) . |
| SECAM COLOUR | Value (A) in the figure: Set to -5V (W & G) . |
| NTSC 3.58 COLOUR | Value (A) in the figure: Set to +6V (W & G) . |

Adjustment of SUB TINT-II (Page 23)

| Adjustment part | Description |
|-----------------|--|
| 6. TINT | |
| NTSC 3.58 TINT | Value (B) in the figure: Set to +6V (W & Cy) . |

■ DEFLECTION CIRCUIT ADJUSTMENT (Page 25)

[DEFLECTION ADJUSTMENTS INITIAL SETTING VALUE (SUB MENU 4. DEF)]

| Setting item | Adjustment name | Initial setting value | | | | | |
|--------------|--|-----------------------|------|------|------|------|------|
| | | REGULAR | | ZOOM | | 16:9 | |
| | | 50Hz | 60Hz | 50Hz | 60Hz | 50Hz | 60Hz |
| 1. V-SHIFT | Vertical shift | -3 | 0 | +1 | 0 | -1 | 0 |
| 2. V-SIZE | Vertical size | +13 | 0 | +36 | +35 | -37 | -37 |
| 3. SUBTITLE | Subtitle | 0 | +1 | 0 | +7 | 0 | 0 |
| 4. H-CENT | Horizontal center | -9 | +5 | -1 | -1 | 0 | 0 |
| 5. H-SIZE | Horizontal size | +11 | -1 | -9 | -7 | -1 | 0 |
| 6. EW-PIN | Side pin correction | -1 | -1 | -4 | -5 | +2 | +1 |
| 7. TRAPEZ | Trapezoidal distortion correction | +4 | -1 | 0 | 0 | -1 | +1 |
| 8. EW.COR.L | Corner pin correction Low side | -2 | 0 | 0 | 0 | +1 | +1 |
| 9. EW.COR.H | Corner pin correction High side | -2 | 0 | 0 | 0 | +1 | +1 |
| 10. V.S-COR | Vertical size correction | +9 | 0 | 0 | 0 | 0 | 0 |
| 11. V-LIN | Vertical Linearity | 0 | 0 | +1 | 0 | 0 | 0 |
| 12. H-BLK-R | Horizontal Blanking Right | 0 | 0 | 0 | 0 | +29 | 0 |
| 13. H-BLK-L | Horizontal Blanking Left | 0 | 0 | 0 | 0 | 0 | 0 |
| 14. V-EHT | V size correction level caused by EHT change | -4 | 0 | 0 | 0 | 0 | 0 |
| 15. H-EHT | H size correction level caused by EHT change | -4 | 0 | 0 | 0 | 0 | 0 |
| 16. EHT-GAIN | Size correction gain caused by EHT change | 0 | 0 | 0 | 0 | 0 | 0 |

: Do not adjust.

■ AUDIO CIRCUIT ADJUSTMENT (Page 29)

[AUDIO ADJUSTMENTS INITIAL SETTING VALUE (SUB MENU 3. AUDIO)]

| Setting item | Variable range | Fixed value |
|----------------|----------------|-------------|
| 1. ERROR LIMIT | 000H ~ FF0H | 100H |
| 2. A2 ID THR | 00H ~ FFH | 14H |
| 3. BASS | -17 ~ +17 | +0 |
| 4. TREBLE | -17 ~ +17 | +0 |

: Do not adjust.



JVC

VICTOR COMPANY OF JAPAN, LIMITED

TELEVISION RECEIVER DIVISION 1106 Heta, Iwai-city, Ibaraki-prefecture, 306-0698, Japan

